

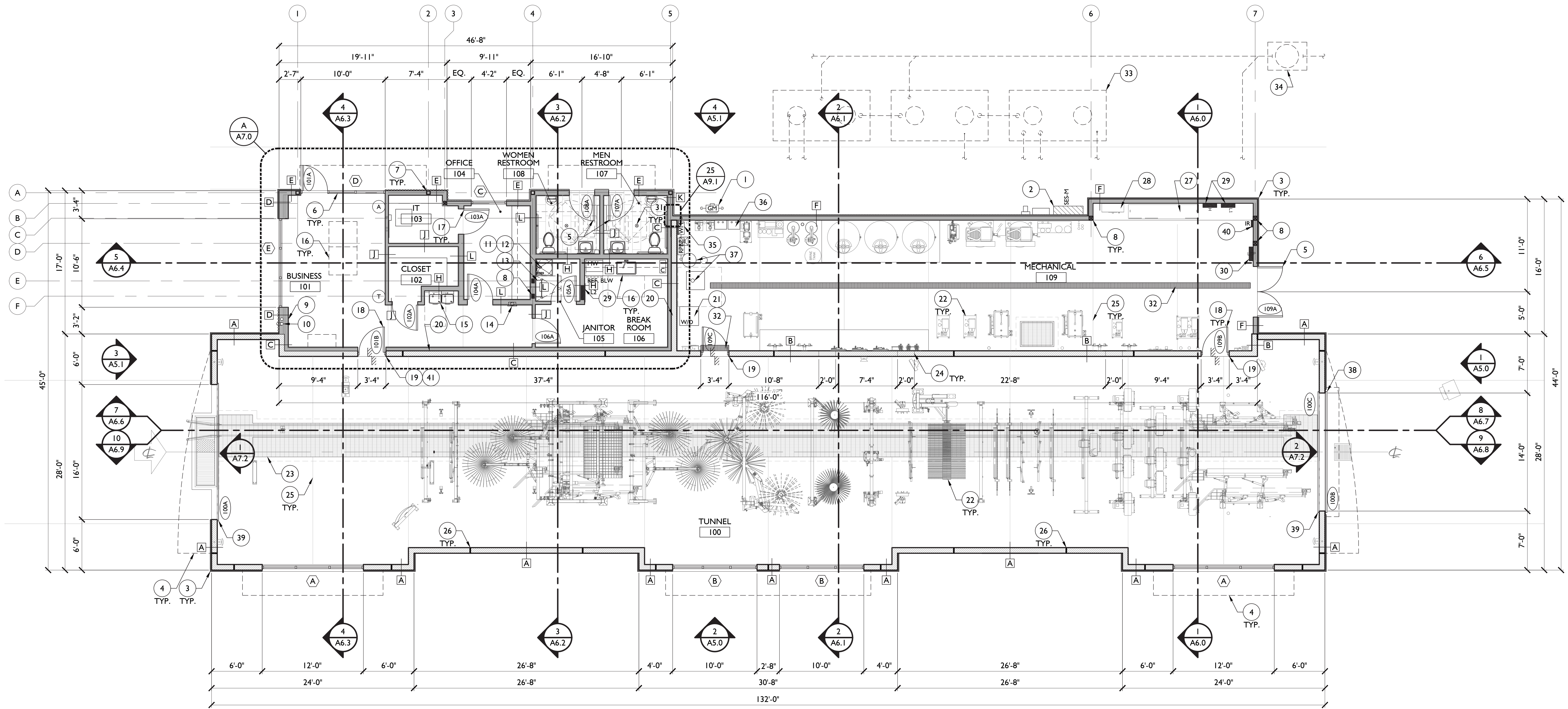

June 6, 2022
MCW Hickman IA1724
Elevations and Materials









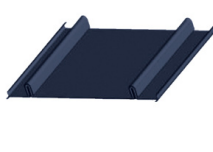

1 **FLOOR PLAN**
3/16" = 1'

MATERIAL TAKE OFF

Exterior Building Finishes - 7,240 sqft - 100%

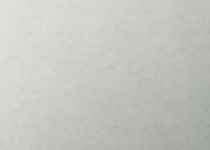
- Primary Materials:**
- A. (SV-1) Natural Stone (Veneer) - 4,009 sqft - 55%
 - B. (CU-1) CMU - 986 sqft - 14%
- Secondary Materials:**
- C. (EIFS) EIFS - 1,329 sqft - 18%
- Openings + Fenestration:**
- D. (ALU) Store Front and Glass - 511 sqft - 7%
 - E. Polycarbonate Overhead Doors - 327 sqft - 5%
 - F. Painted Hollow Metal Doors - 93 sqft - 1%

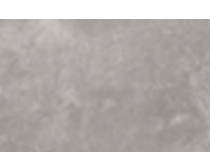
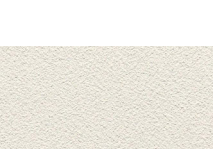
FINISH LEGEND

MP-4		METAL PANEL - CTRMS / PRE-FINISHED STANDING SEAM METAL ROOF / 436B3488 FLUROPON IN THE NAVY	CU-1		SPLIT FACE INTEGRALLY COLORED BLOCK - COLOR TO BE CLOSE TO MORNING FOG SW6255
SV-1		STONE VENEER - ELDORADO / VANTAGE 30 / WHITE ELM	CU-2		SPLIT FACE INTEGRALLY COLORED BLOCK - COLOR TO BE CLOSE TO WALL STREET SW7665
PT-9		EXTERIOR PAINT - SHERWIN-WILLIAMS / IN THE NAVY SW9178	ALU		WINDOWS & DOORS - THERMALLY BROKEN ANODIZED ALUMINUM / CLEAR
PT-6		EXTERIOR PAINT - SHERWIN-WILLIAMS / MORNING FOG SW6225	CON		CONCRETE / STANDARD GRAY
EIFS		EXTERIOR INSULATION FINISHING SYSTEM	PT-3		EXTERIOR PAINT - SHERWIN-WILLIAMS / WALL STREET SW7665
			PT-7		EXTERIOR PAINT - SHERWIN-WILLIAMS / DRESS BLUES SW9176

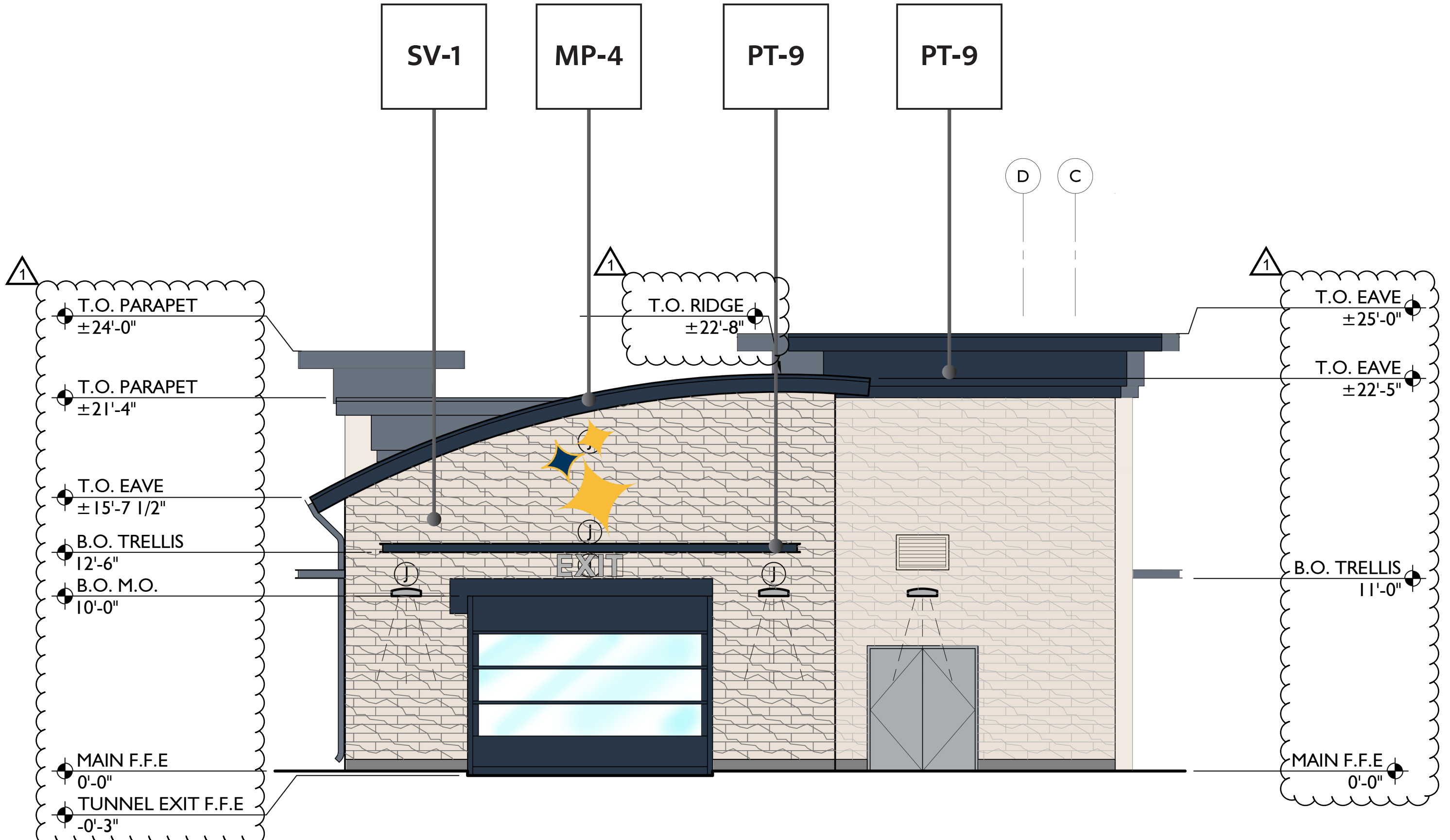

NORTH ELEVATION: CAR WASH TUNNEL EXIT

3/16" = 1'

REVISIONS



CITY COMMENTS 06.06.2022

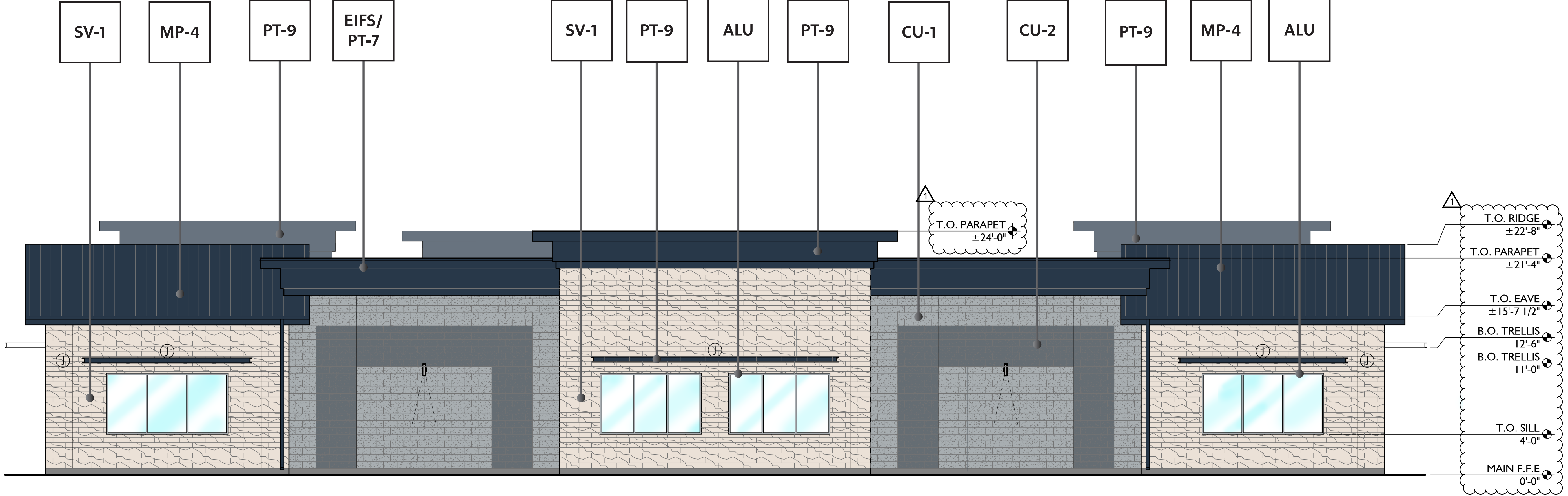

EAST ELEVATION: CAR WASH TUNNEL WALL

3/16" = 1'

MATERIAL TAKE OFF

Exterior Building Finishes - 7,240 sqft - 100%

- Primary Materials:**
- A. (SV-1) Natural Stone (Veneer) - 4,009 sqft - 55%
 - B. (CU-1) CMU - 986 sqft - 14%
- Secondary Materials:**
- C. (EIFS) EIFS - 1,329 sqft - 18%
- Openings + Fenestration:**
- D. (ALU) Store Front and Glass - 511 sqft - 7%
 - E. Polycarbonate Overhead Doors - 327 sqft - 5%
 - F. Painted Hollow Metal Doors - 93 sqft - 1%

FINISH LEGEND

MP-4		METAL PANEL - CTRMS / PRE-FINISHED STANDING SEAM METAL ROOF / 436B3488 FLUROPON IN THE NAVY	CU-1		SPLIT FACE INTEGRALLY COLORED BLOCK - COLOR TO BE CLOSE TO MORNING FOG SW6255
SV-1		STONE VENEER - ELDORADO / VANTAGE 30 / WHITE ELM	CU-2		SPLIT FACE INTEGRALLY COLORED BLOCK - COLOR TO BE CLOSE TO WALL STREET SW7665
PT-9		EXTERIOR PAINT - SHERWIN-WILLIAMS / IN THE NAVY SW9178	ALU		WINDOWS & DOORS - THERMALLY BROKEN ANODIZED ALUMINUM / CLEAR
PT-6		EXTERIOR PAINT - SHERWIN-WILLIAMS / MORNING FOG SW6225	CON		CONCRETE / STANDARD GRAY
EIFS		EXTERIOR INSULATION FINISHING SYSTEM	PT-3		EXTERIOR PAINT - SHERWIN-WILLIAMS / WALL STREET SW7665
			PT-7		EXTERIOR PAINT - SHERWIN-WILLIAMS / DRESS BLUES SW9176



SOUTH ELEVATION: CAR WASH TUNNEL ENTRANCE

4
3/16" = 1'

REVISIONS





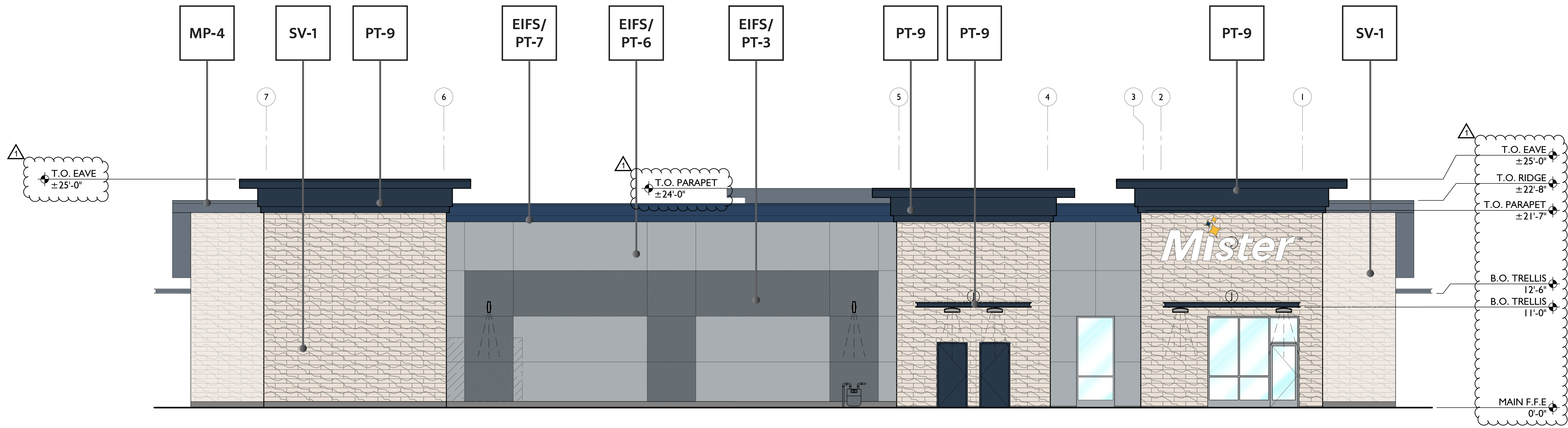

CITY COMMENTS 06.06.2022



WEST ELEVATION: BUSINESS/ MECHANICAL

5
3/16" = 1'

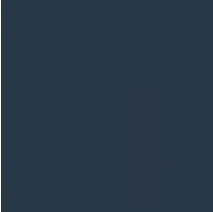
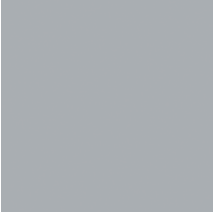
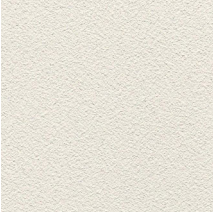
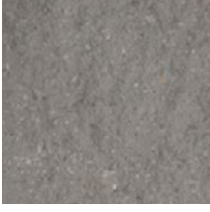
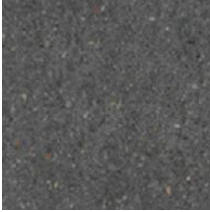
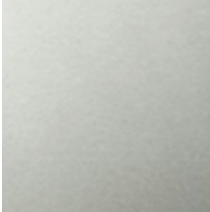
FINISH LEGEND

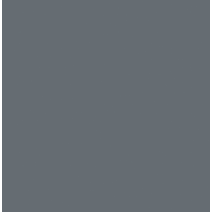
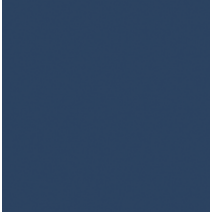
<p>MP-4  METAL PANEL - CTRMS / PRE-FINISHED STANDING SEAM METAL ROOF / 436B3488 FLUOROPON IN THE NAVY</p> <p>SV-1  STONE VENEER - ELDORADO / VANTAGE 30 / WHITE ELM</p> <p>PT-9  EXTERIOR PAINT - SHERWIN-WILLIAMS / IN THE NAVY SW9178</p> <p>PT-6  EXTERIOR PAINT - SHERWIN-WILLIAMS / MORNING FOG SW6225</p> <p>EIFS  EXTERIOR INSULATION FINISHING SYSTEM</p>	<p>CU-1  SPLIT FACE INTEGRALLY COLORED BLOCK - COLOR TO BE CLOSE TO MORNING FOG SW6255</p> <p>CU-2  SPLIT FACE INTEGRALLY COLORED BLOCK - COLOR TO BE CLOSE TO WALL STREET SW7665</p> <p>ALU  WINDOWS & DOORS - THERMALLY BROKEN ANODIZED ALUMINUM / CLEAR</p> <p>CON  CONCRETE / STANDARD GRAY</p> <p>PT-3  EXTERIOR PAINT - SHERWIN-WILLIAMS / WALL STREET SW7665</p> <p>PT-7  EXTERIOR PAINT - SHERWIN-WILLIAMS / DRESS BLUES SW9176</p>
-------------------------------------------------------------------------------------------------------------------------------------------------------------------------------------------------------------------------------------------------------------------------------------------------------------------------------------------------------------------------------------------------------------------------------------------------------------------------------------------------------------------------------------------------------------------------------------------------------------------------------------------------------------------------------------------------------------------------------------------------------------------------------------------------------------------------------------	-------------------------------------------------------------------------------------------------------------------------------------------------------------------------------------------------------------------------------------------------------------------------------------------------------------------------------------------------------------------------------------------------------------------------------------------------------------------------------------------------------------------------------------------------------------------------------------------------------------------------------------------------------------------------------------------------------------------------------------------------------------------------------------------------------------------------------------------------------------------------------------------------------------------------------------------------------------------------------------------------------------

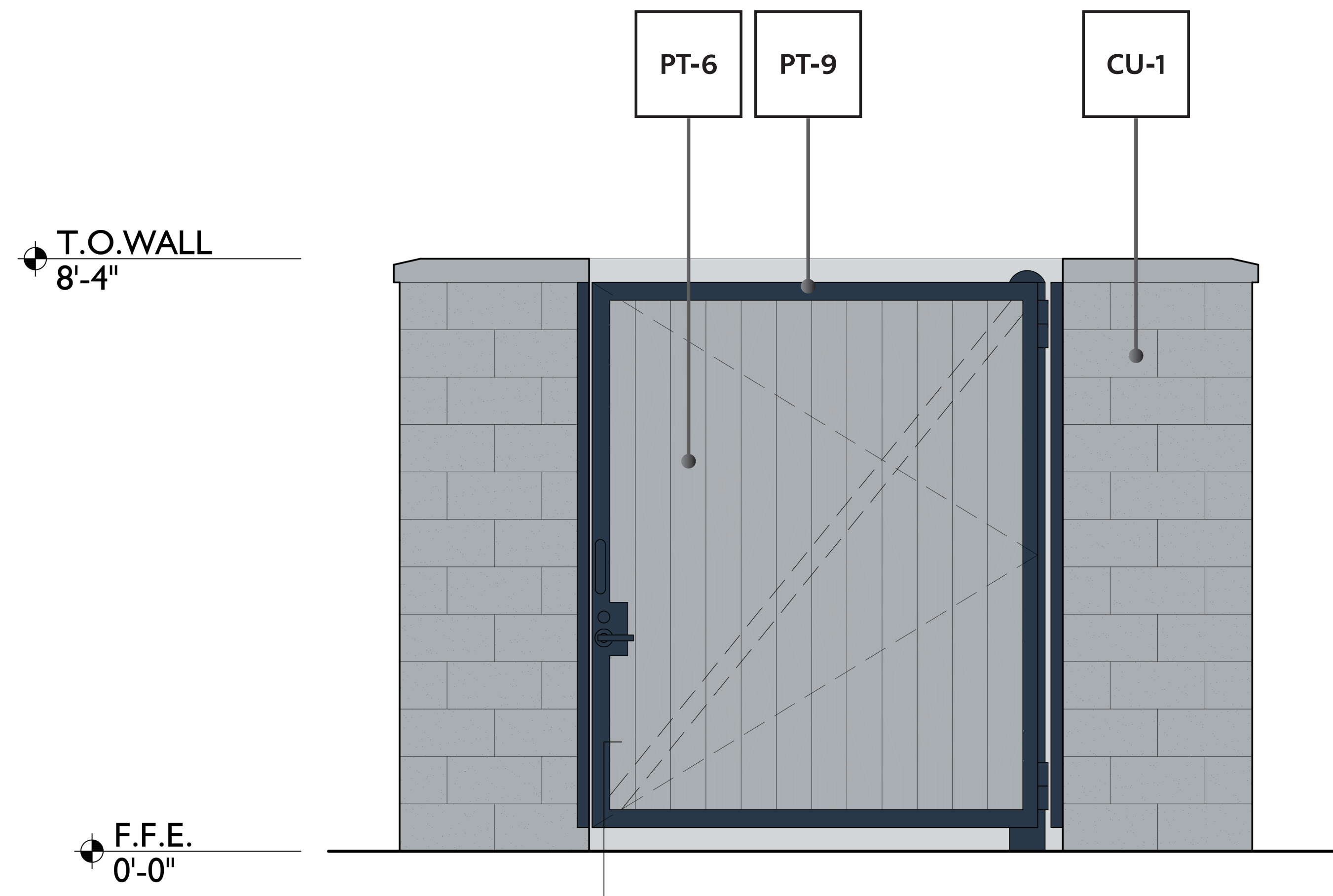
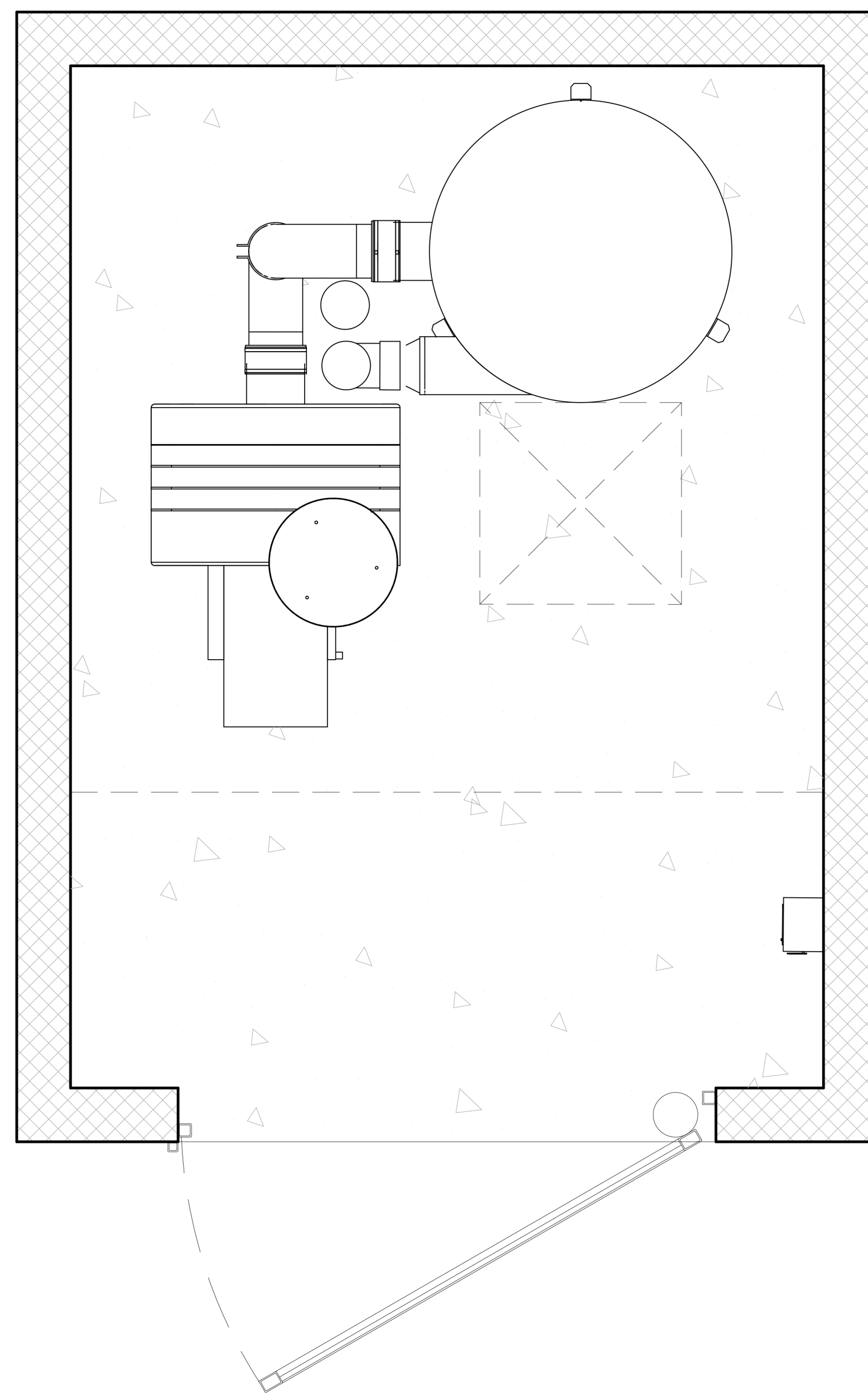







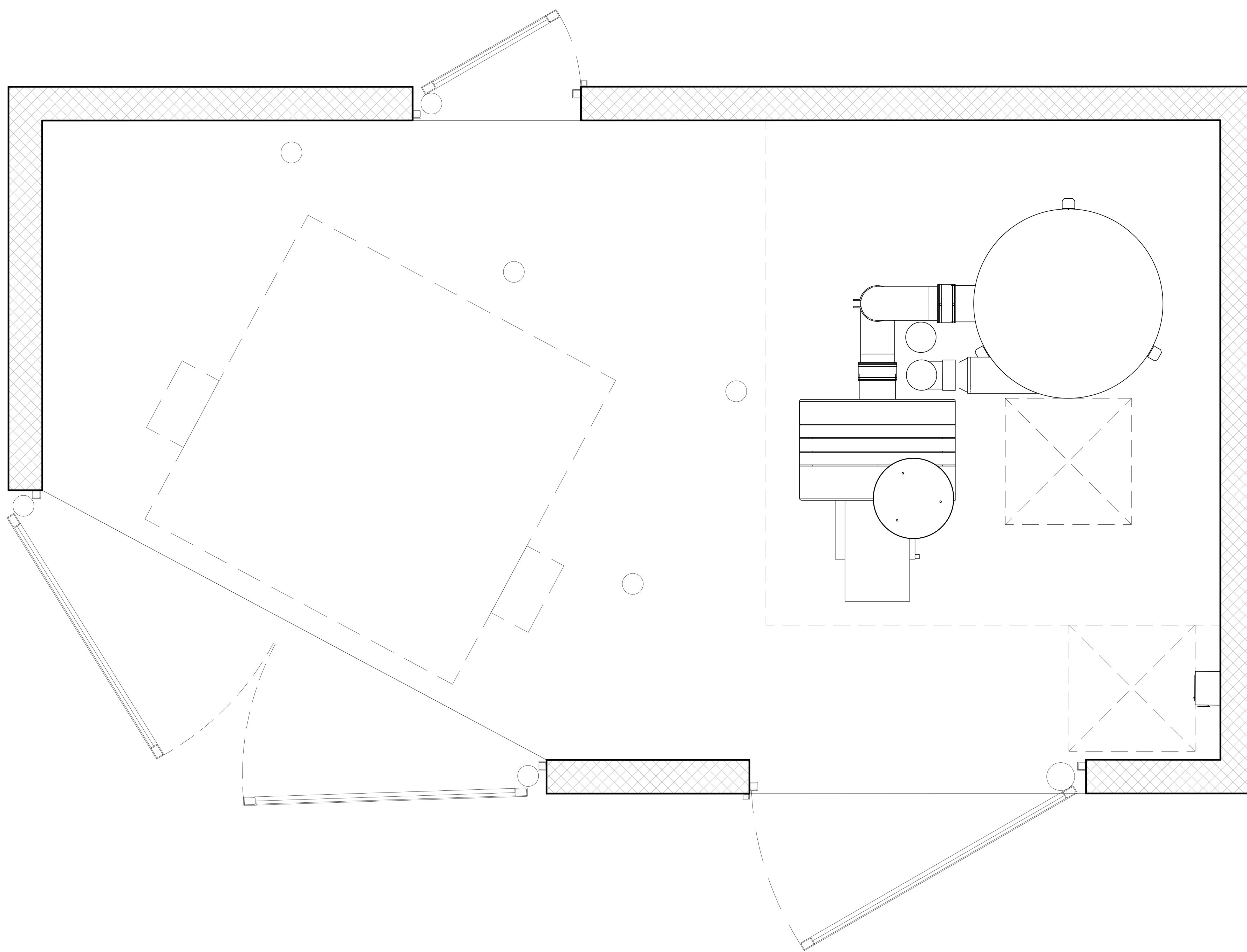

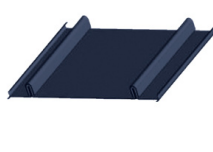

6

VACUUM ENCLOSURE ELEVATIONS AND PLAN

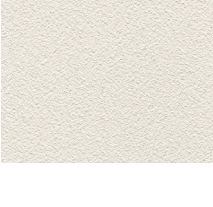
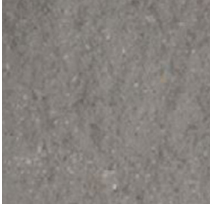
3/4" = 1'-0"

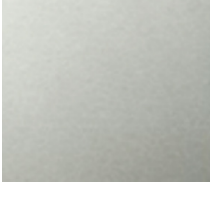

FINISH LEGEND

<p>MP-4  METAL PANEL - CTRMS / PRE-FINISHED STANDING SEAM METAL ROOF / 436B3488 FLUROPON IN THE NAVY</p> <p>SV-1  STONE VENEER - ELDORADO / VANTAGE 30 / WHITE ELM</p> <p>PT-9  EXTERIOR PAINT - SHERWIN-WILLIAMS / IN THE NAVY SW9178</p> <p>PT-6  EXTERIOR PAINT - SHERWIN-WILLIAMS / MORNING FOG SW6225</p> <p>EIFS  EXTERIOR INSULATION FINISHING SYSTEM</p>	<p>CU-1  SPLIT FACE INTEGRALLY COLORED BLOCK - COLOR TO BE CLOSE TO MORNING FOG SW6255</p> <p>CU-2  SPLIT FACE INTEGRALLY COLORED BLOCK - COLOR TO BE CLOSE TO WALL STREET SW7665</p> <p>ALU  WINDOWS & DOORS - THERMALLY BROKEN ANODIZED ALUMINUM / CLEAR</p> <p>CON  CONCRETE / STANDARD GRAY</p> <p>PT-3  EXTERIOR PAINT - SHERWIN-WILLIAMS / WALL STREET SW7665</p> <p>PT-7  EXTERIOR PAINT - SHERWIN-WILLIAMS / DRESS BLUES SW9176</p>
------------------------------------------------------------------------------------------------------------------------------------------------------------------------------------------------------------------------------------------------------------------------------------------------------------------------------------------------------------------------------------------------------------------------------------------------------------------------------------------------------------------------------------------------------------------------------------------------------------------------------------------------------------------------------------------------------------------------------------------------------------------------------------------------------------------------------------	-------------------------------------------------------------------------------------------------------------------------------------------------------------------------------------------------------------------------------------------------------------------------------------------------------------------------------------------------------------------------------------------------------------------------------------------------------------------------------------------------------------------------------------------------------------------------------------------------------------------------------------------------------------------------------------------------------------------------------------------------------------------------------------------------------------------------------------------------------------------------------------------------------------------------------------------------------------------------------------------------------------

DUMPSTER AND VACUUM ENCLOSURE PLAN

7

3/4" = 1'-0"

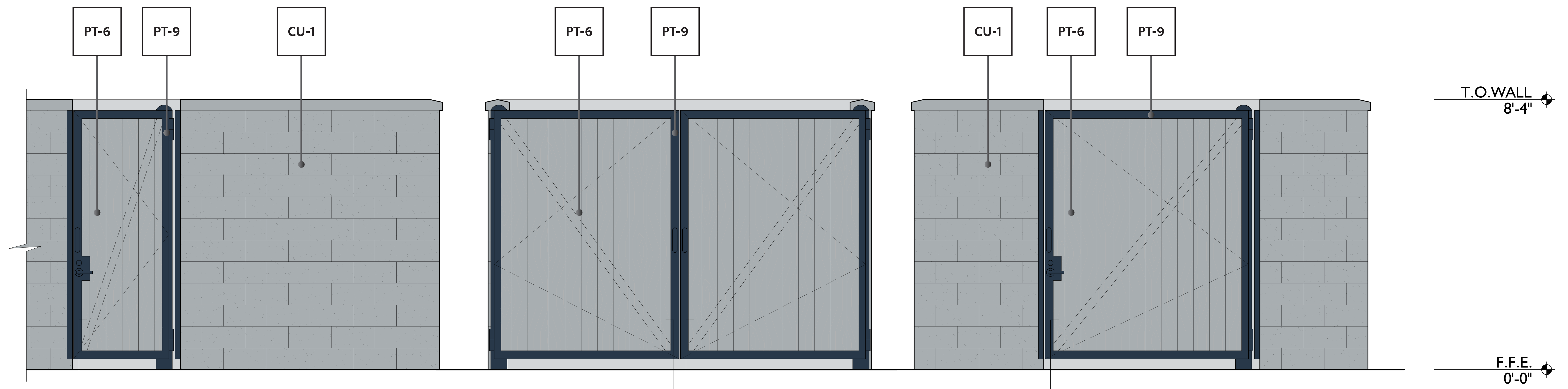

DUMPSTER AND VACUUM ENCLOSURE ELEVATIONS

8

3/4" = 1'-0"

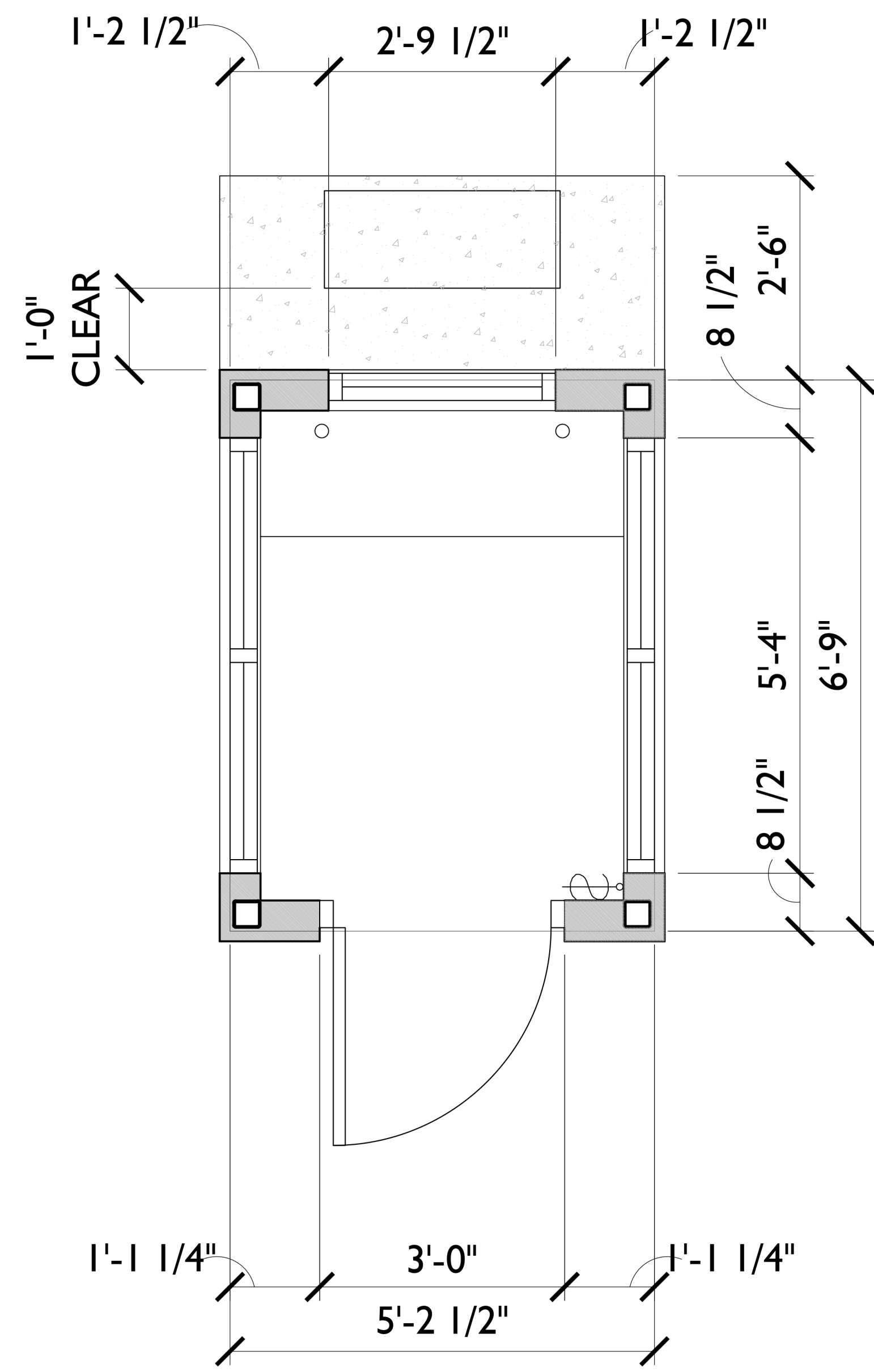

T.O. ROOF
10'-2"

F.F.E.
0'-0"

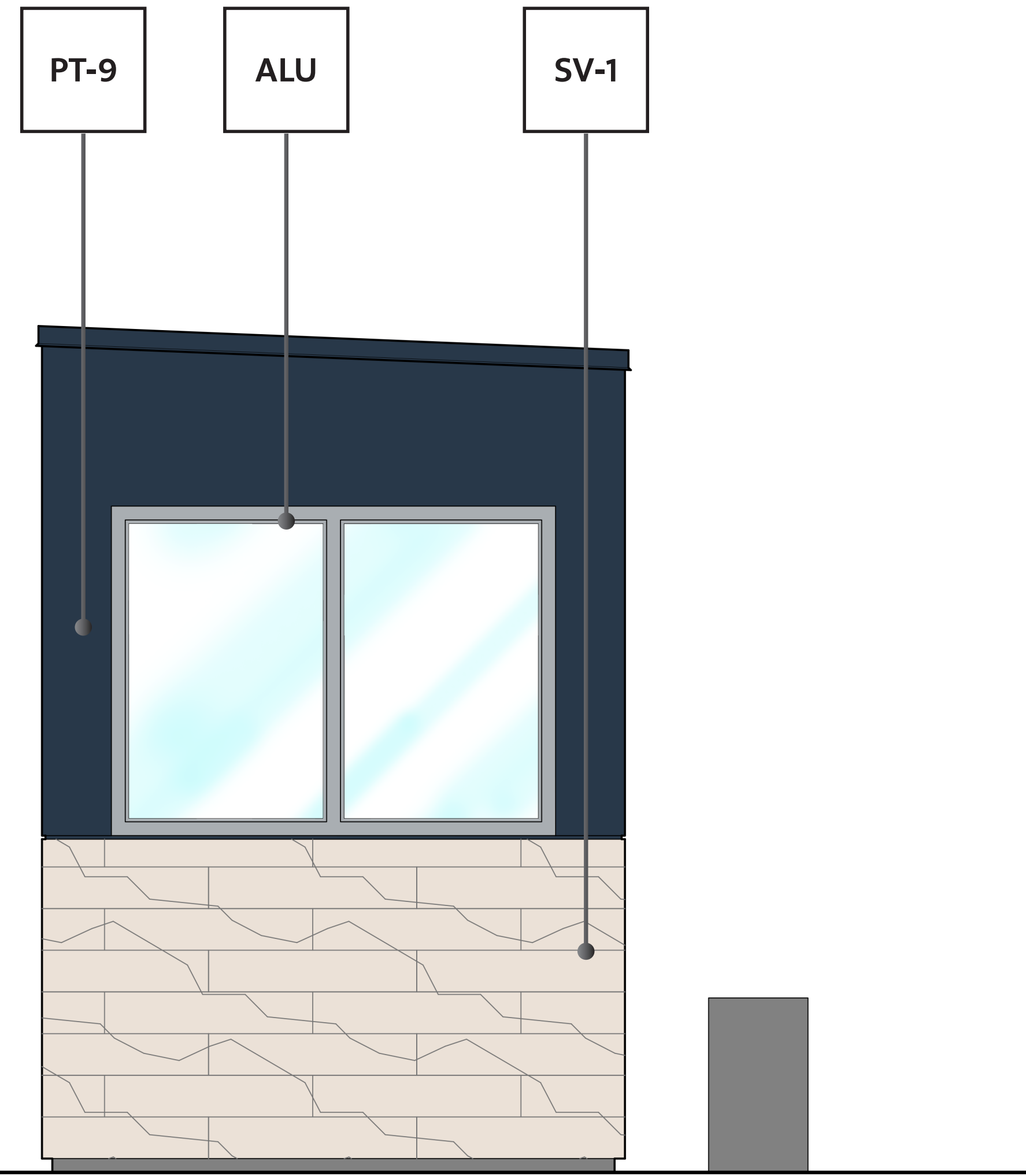

FINISH LEGEND

MP-4		METAL PANEL - CTRMS / PRE-FINISHED STANDING SEAM METAL ROOF / 436B3488 FLUROPON IN THE NAVY	CU-1		SPLIT FACE INTEGRALLY COLORED BLOCK - COLOR TO BE CLOSE TO MORNING FOG SW6255
SV-1		STONE VENEER - ELDORADO / VANTAGE 30 / WHITE ELM	CU-2		SPLIT FACE INTEGRALLY COLORED BLOCK - COLOR TO BE CLOSE TO WALL STREET SW7665
PT-9		EXTERIOR PAINT - SHERWIN-WILLIAMS / IN THE NAVY SW9178	ALU		WINDOWS & DOORS - THERMALLY BROKEN ANODIZED ALUMINUM / CLEAR
PT-6		EXTERIOR PAINT - SHERWIN-WILLIAMS / MORNING FOG SW6225	CON		CONCRETE / STANDARD GRAY
EIFS		EXTERIOR INSULATION FINISHING SYSTEM	PT-3		EXTERIOR PAINT - SHERWIN-WILLIAMS / WALL STREET SW7665
			PT-7		EXTERIOR PAINT - SHERWIN-WILLIAMS / DRESS BLUES SW9176

9 ATTENDANT SHELTER PLAN

3/4" = 1'

10 ATTENDANT SHELTER SIDE ELEVATION

3/4" = 1'

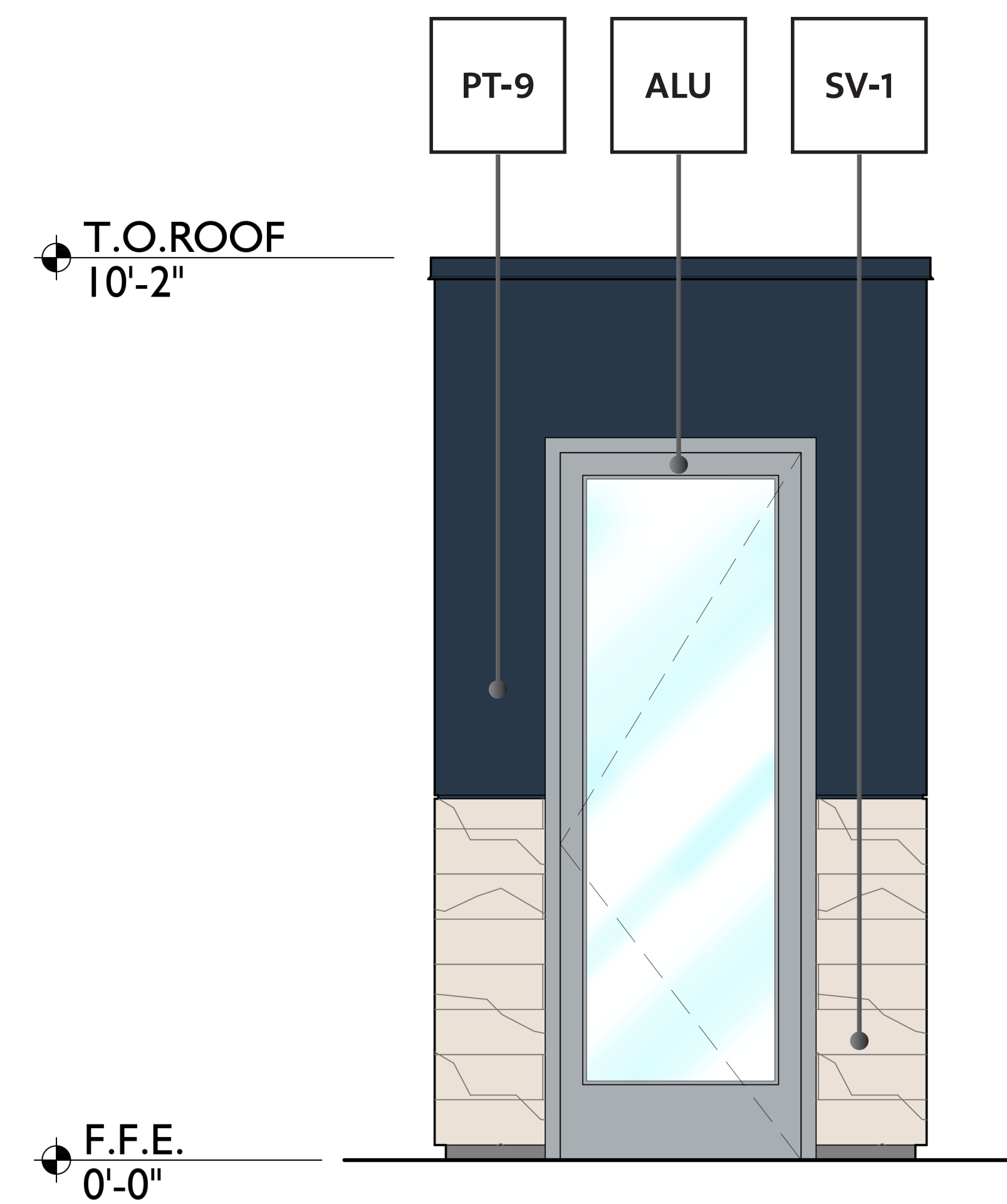

11 ATTENDANT SHELTER FRONT ELEVATION

3/4" = 1'

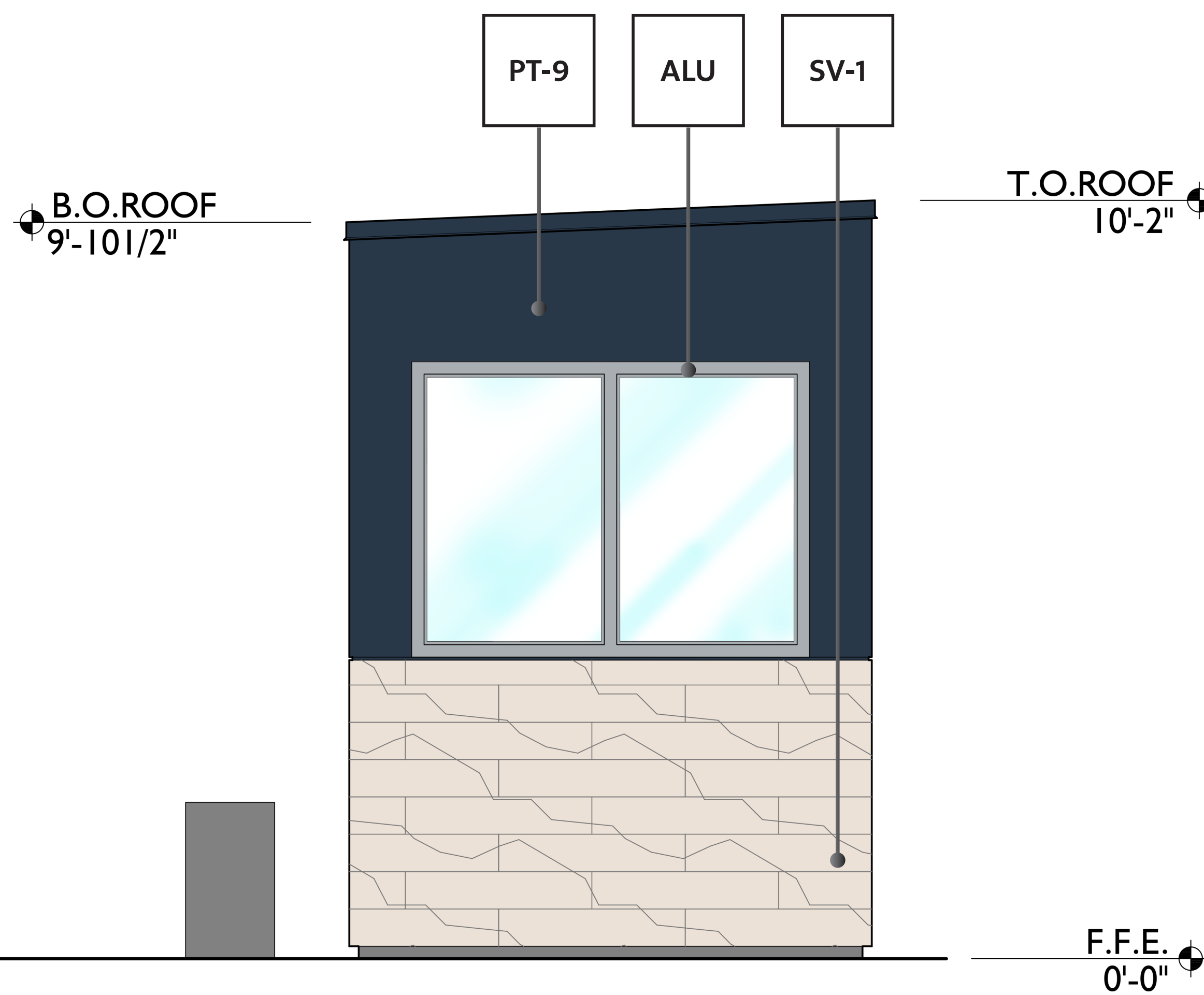

12 ATTENDANT SHELTER SIDE ELEVATION

3/4" = 1'

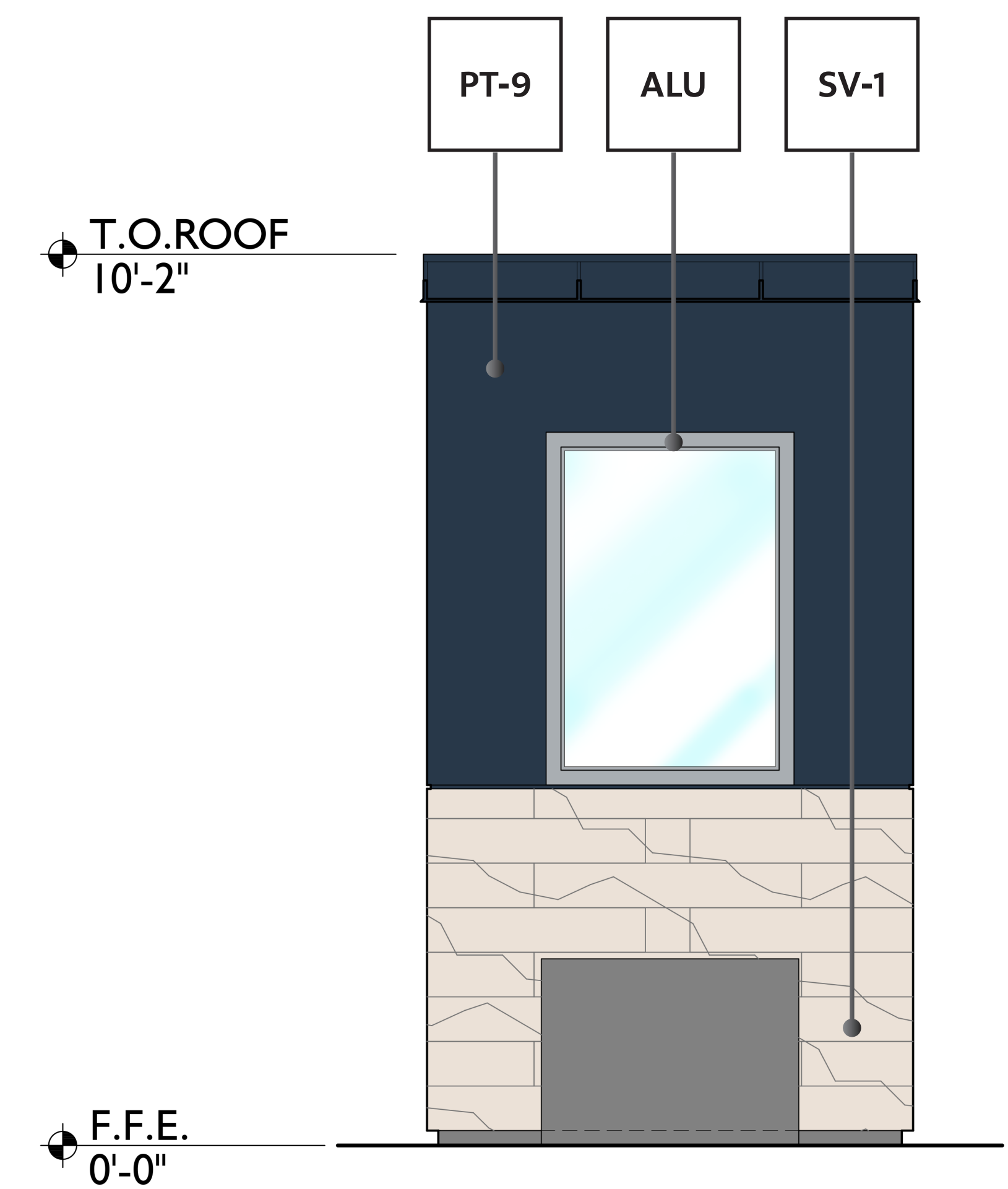

13 ATTENDANT SHELTER READ ELEVATION

3/4" = 1'

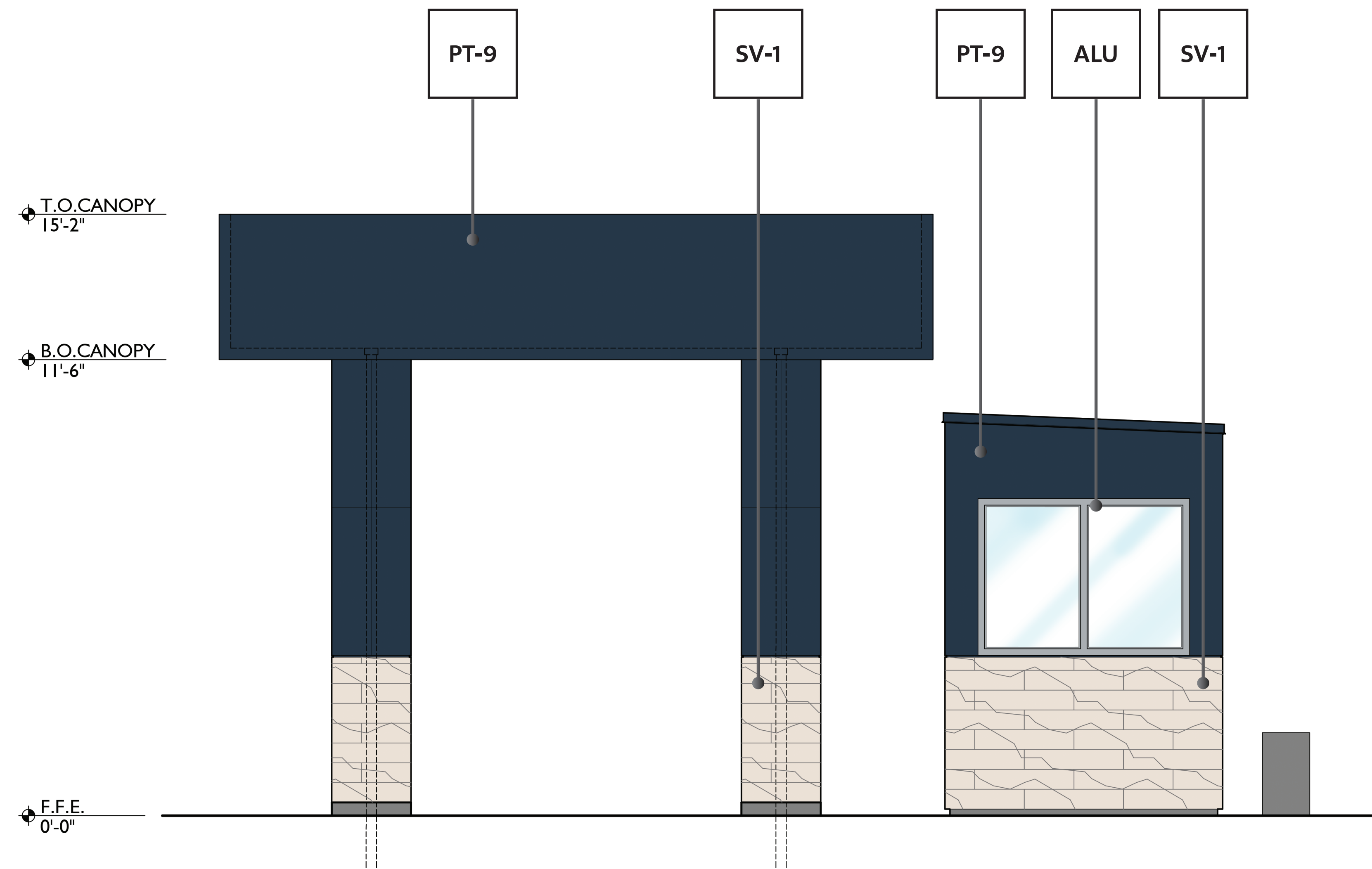

FINISH LEGEND

<p>MP-4 METAL PANEL - CTRMS / PRE-FINISHED STANDING SEAM METAL ROOF / 436B3488 FLUROPON IN THE NAVY</p> <p>SV-1 STONE VENEER - ELDORADO / VANTAGE 30 / WHITE ELM</p> <p>PT-9 EXTERIOR PAINT - SHERWIN-WILLIAMS / IN THE NAVY SW9178</p> <p>PT-6 EXTERIOR PAINT - SHERWIN-WILLIAMS / MORNING FOG SW6225</p> <p>EIFS EXTERIOR INSULATION FINISHING SYSTEM</p>	<p>CU-1 SPLIT FACE INTEGRALLY COLORED BLOCK - COLOR TO BE CLOSE TO MORNING FOG SW6255</p> <p>CU-2 SPLIT FACE INTEGRALLY COLORED BLOCK - COLOR TO BE CLOSE TO WALL STREET SW7665</p> <p>ALU WINDOWS & DOORS - THERMALLY BROKEN ANODIZED ALUMINUM / CLEAR</p> <p>CON CONCRETE / STANDARD GRAY</p> <p>PT-3 EXTERIOR PAINT - SHERWIN-WILLIAMS / WALL STREET SW7665</p> <p>PT-7 EXTERIOR PAINT - SHERWIN-WILLIAMS / DRESS BLUES SW9176</p>
-----------------------------------------------------------------------------------------------------------------------------------------------------------------------------------------------------------------------------------------------------------------------------------------------------------------------------------------------------------------------------------------------------	-------------------------------------------------------------------------------------------------------------------------------------------------------------------------------------------------------------------------------------------------------------------------------------------------------------------------------------------------------------------------------------------------------------------------------------------------------------------------------------------

14 **POS CANOPY SIDE ELEVATION**
1/2" = 1'

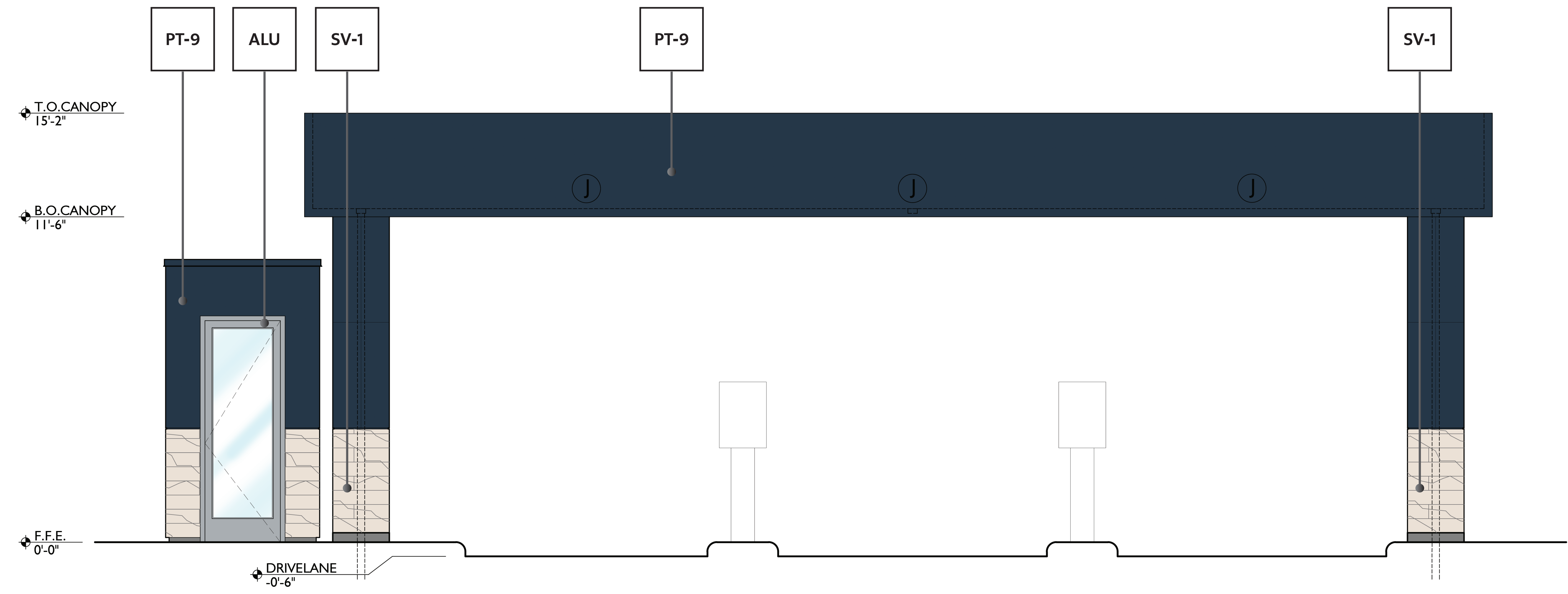

15 **POS CANOPY FRONT ELEVATION**
1/2" = 1'